

# RTD

## Thermodynamic recovery unit with integrated heat pump

Air flow rate 1100 - 3200 m<sup>3</sup>/h



- Compact dimensions
- Compressor with inverter
- EC fan Plug-fan
- Fixed point adjustment in delivery
- Horizontal installation

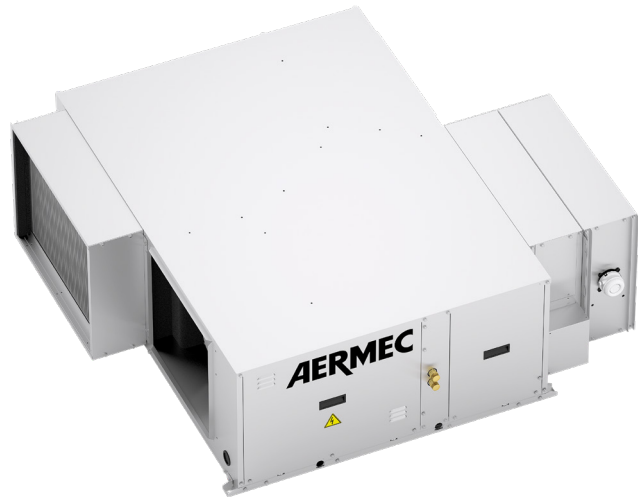

### DESCRIPTION

Is an air replacement, filtration and treatment unit equipped with high efficiency thermodynamic recovery performed by an integrated cooling circuit.

The inverter compressor allows a high energy saving at the same time as maintaining the set delivery temperature.

The unit can be integrated in the direct expansion and hydronic systems both in heating and cooling mode.

### FEATURES

#### Versions

##### Horizontal installation:

- **RTD:** Standard unit with constant flow-rate control.
- **RTD\_Q:** Units with flow modulation according to the concentration of CO<sub>2</sub>
- **RTD\_W:** Unit with internal hot/cold water coil complete with three-way valve, modulating servo-control and anti-freeze thermostat.

#### Main components

- Cooling circuit **BLDC inverter compressor**.
- Plug fans with EC inverter motor.
- Safety valve.
- Lower sandwich panels in galvanised sheet metal with injected polyurethane insulation; upper and side panel in galvanised sheet metal internally lined with insulating mat
- Synthetic filter class Coarse 85% according to EN16890 on the outside air inlet complete with fouling detection pressure switch.

- Condensate collection tank in aluminium alloy with side discharge.

### Regulation

- **Power and control electrical panel** on the machine.
- Programmable controller able to manage all the advanced functions present on the unit (with fixed point adjustment in delivery; cooling, heating, automatic, free cooling functions; compressor, fans and eventual water coil modulation).
- **Remote panel (mandatory accessory)** in graphic display version or Touch version.

### ACCESSORIES

**CPVR:** Recovery fan constant air flow rate control (accessory supplied separately; the function is enabled on the controller).

**PRGD1:** Control panel for wall or flush-mount installation with graphic display. Maximum installation distance of 10m.

**PRGDx:** Touch screen control panel for wall or flush-mount installation complete with black and white frame. Maximum installation distance of 150m.

**MRE:** Single-stage anti-freeze electric heater module 2 kW to be installed on the external air intake (required for outdoor air temperatures below -5° C).

**MF:** Coarse 85% efficiency filters module (EN16890) to be positioned in recovery (side extraction) complete with filter clogging pressure switch.

*The remote controller is required for unit operation, it is possible to select between PRGD1 and PRGDx.*

## ACCESSORIES COMPATIBILITY

### Recovery fan constant air flow rate control and xontrol panel

Model	Ver	11	14	17	21	26	32
CPVR (1)	.,Q,QW,W	•	•	•	•	•	•
PRGD1 (2)	.,Q,QW,W	•	•	•	•	•	•
PRGD1X	.,Q,QW,W	•	•	•	•	•	•

(1) Accessory supplied separately.

(2) The remote controller is required for unit operation, it is possible to select between PRGD1 and PRGD1X.

### Anti-freeze electric heater module

Model	Ver	11	14	17	21	26	32
MRE2M	.,Q,QW,W	•	•				
MRE3M	.,Q,QW,W			•			
MRE3T	.,Q,QW,W				•		
MREST	.,Q,QW,W					•	•

### Coarse 85% efficiency filters module (EN16890)

Model	Ver	11	14	17	21	26	32
MFSR1	.,Q,QW,W	•	•				
MFSR2	.,Q,QW,W			•	•		
MFSR3	.,Q,QW,W					•	•
MF7M1	.,Q,QW,W	•	•				
MF7M2	.,Q,QW,W			•	•		
MF7M3	.,Q,QW,W					•	•

## CONFIGURATOR

Field	Description
<b>1,2,3</b>	<b>RTD</b>
<b>4,5</b>	<b>Size</b> 11, 14, 17, 21, 26, 32
<b>6</b>	<b>Ventilation control type</b>
°	Constant flow (standard unit)
Q	Control via air quality probe
<b>7</b>	<b>Internal hot/cold water coil</b>
°	No coil (standard unit)
W	Internal water coil

## PERFORMANCE SPECIFICATIONS

		RTD11	RTD14	RTD17	RTD21	RTD26	RTD32
<b>Air flow rates</b>							
Nominal air flow rate	m <sup>3</sup> /h	1100	1400	1700	2100	2600	3200
Minimum air flow rate	m <sup>3</sup> /h	950	1200	1450	1800	2200	2700
Maximum air flow rate	m <sup>3</sup> /h	1200	1550	1850	2300	2850	3500
<b>Delivery fan</b>							
Type	type	Plug-fan	Plug-fan	Plug-fan	Plug-fan	Plug-fan	Plug-fan
Fan motor	type	EC Inverter motors	EC Inverter motors	EC Inverter motors	EC Inverter motors	EC Inverter motors	EC Inverter motors
Number	no.	1	1	1	1	1	1
Nominal useful head	Pa	150	150	150	150	150	150
Maximum useful head	Pa	510	580	520	360	570	380
Cooling input power	kW	0,19	0,20	0,23	0,32	0,43	0,62
Heating input power	kW	0,18	0,18	0,22	0,30	0,39	0,56
<b>Expulsion fan</b>							
Type	type	Plug-fan	Plug-fan	Plug-fan	Plug-fan	Plug-fan	Plug-fan
Fan motor	type	EC Inverter motors	EC Inverter motors	EC Inverter motors	EC Inverter motors	EC Inverter motors	EC Inverter motors
Number	no.	1	1	1	1	1	1
Nominal useful head	Pa	150	150	150	150	150	150
Maximum useful head	Pa	530	600	520	370	590	400
Cooling input power	kW	0,17	0,16	0,19	0,27	0,33	0,46
Heating input power	kW	0,18	0,18	0,22	0,31	0,39	0,54
<b>Performance in cooling mode at maximum compressor speed (1)</b>							
Cooling capacity	kW	6,70	8,00	8,80	11,20	14,10	16,30
Sensible cooling capacity	kW	5,70	6,80	7,80	9,80	12,10	13,80
Compressors absorbed power	kW	1,80	2,20	2,30	3,20	4,00	4,50
Total input power EN14511 2017	kW	2,09	2,43	2,58	3,55	4,48	5,15
EER EN14511:2017	W/W	3,20	3,30	3,42	3,16	3,14	3,16
EER	W/W	3,11	3,15	3,24	2,96	2,95	2,92
<b>Performance in heating mode at maximum compressor speed</b>							
Heating capacity	kW	7,70	9,30	10,60	13,80	16,90	20,00
Compressors absorbed power	kW	1,60	2,00	2,20	2,90	3,30	4,10
COP refrigerant circuit	W/W	4,83	4,64	4,82	4,74	5,12	4,87
COP EN14511:2017 (2)	W/W	4,07	4,13	4,26	4,20	4,45	4,18
COP	W/W	3,94	3,92	4,02	3,91	4,15	3,84
Total input power EN14511 2017	kW	1,90	2,20	2,50	3,30	3,80	4,80
Total input power	kW	2,00	2,40	2,60	3,50	4,10	5,20
<b>Compressor</b>							
Type	type	Twin-rotary BLDC	Twin-rotary BLDC	Twin-rotary BLDC	Twin-rotary BLDC	Twin-rotary BLDC	Twin-rotary BLDC
Compressor regulation	Type	Inverter	Inverter	Inverter	Inverter	Inverter	Inverter
Number	no.	1	1	1	1	1	1
Refrigerant	type	R410A	R410A	R410A	R410A	R410A	R410A
<b>Electric data</b>							
Input power at full load	kW	4,30	4,50	4,50	5,30	6,10	6,10
Input current at full load	A	14,40	13,80	13,80	17,90	16,90	16,90
<b>Power supply</b>							
Power supply		230V 50Hz	230V 50Hz	230V 50Hz	400V 3N 50Hz	400V 3N 50Hz	400V 3N 50Hz

(1) Cooling mode: aire temperature 35°C Tbs / 24 °C Tbh ; ambient air 27°C Tbs /19°C Tbh .

(2) Heating mode: aire temperature 7°C Tbs / 6°C Tbh ; ambient air 20°C Tbs /15°C Tbh.

## DIMENSIONS

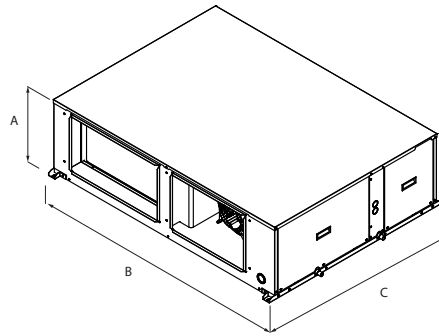

Size			11	14	17	21	26	32
<b>Dimensions and weights</b>								
A	.,Q,QW,W	mm	430	430	530	530	630	630
B	.,Q,QW,W	mm	1508	1508	1508	1508	1508	1508
C	.,Q,QW,W	mm	1100	1100	1100	1100	1100	1100
Empty weight	.	kg	133	135	148	160	179	179
	Q	kg	135	137	150	162	181	181
	QW	kg	135	142	161	172	197	197
	W	kg	140	142	159	170	195	195
Weight functioning	.	kg	133	135	148	160	179	179
	Q,QW,W	kg	-	-	-	-	-	-

Aermec reserves the right to make any modifications deemed necessary.  
All data is subject to change without notice. Aermec does not assume responsibility or liability for errors or omissions.

**Aermec S.p.A.**  
Via Roma, 996 - 37040 Bevilacqua (VR) - Italia  
Tel. 0442633111 - Telefax 044293577  
www.aermec.com