

NSG

Air-water chiller

Cooling capacity 228 ÷ 1580 kW



- Microchannel coil
- High efficiency also at partial loads
- Night mode



DESCRIPTION

Air-cooled outdoor chiller designed to meet air conditioning needs in residential/commercial complexes or industrial applications. Outdoor units with high-efficiency screw compressors axial fans, micro-channel external coils and plant side shell and tube heat exchanger. In the unit with desuperheater, it is also possible to produce free-hot water. The base, the structure and the panels are made of galvanized steel treated with polyester paint RAL 9003.

VERSIONS

- ° Standard
- A High efficiency
- E Silenced high efficiency
- L Standard silenced
- N Silenced very high efficiency
- U Very high efficiency

FEATURES

HFO R1234ze refrigerant gas

HFO R1234ze is a mixture featuring:

ODP = 0 and GWP (Global Warming Potential) = 1.37, R134a GWP = 1430,

with thermodynamic properties that guarantee and sometimes improve efficiencies achieved with HFC refrigerants.

Bi-tri circuit unit

Unit with 2/3 refrigerant circuits designed to provide maximum efficiency at full load, ensuring high efficiency at partial loads also and ensuring continuity in case one of the circuits stops.

Aluminium microchannel coils

The microchannel condensing aluminum coils ensure high levels of efficiency, reduced quantities of refrigerant and lower unit weight. The treatment "O" available as configurator it ensures high resistance to corrosion even in the most aggressive environments.

Electronic expansion valve

The possibility to use electronic expansion valve, offers significant benefits, especially when the chiller is working with partial loads, increasing the energy efficiency of the unit.

Integrated hydronic kit

Integrated hydronic kit containing the main hydraulic components; available with various configurations with one or two pumps, high or low head, to obtain a solution that allows you to save money and to facilitate installation.

CONTROL PCO₅

Units include 1 control board for each compressor.

Microprocessor control, with keyboard and LCD display, for easy access on the unit with a menu available in several languages.

- The presence of a programmable timer allows functioning time periods and a possible second set-point to be set.
- The temperature control takes place with the integral proportional logic, based on the water output temperature.
- **Night mode:** only in the **non-silenced versions with the fan to be, inverter or phase-cut or with the DCPX accessory**, a silenced operation profile can be set, which is useful, for example, at night for greater acoustic comfort, but always ensures performance even at peak load hours.
- Possibility to control two units in a Master-Slave configuration (from size 1402 to 6402)

ACCESSORIES

AER485P1: RS-485 interface for supervising systems with MODBUS protocol. 1 accessory is provided for each unit control board.

AERBAC-ONE: Ethernet communication interface for Bacnet/IP and Modbus TCP/IP protocols, HTTPS protocol for web interface, encrypted communication protocols and access credential management in accordance with the latest standards. One accessory is provided for each unit control board.

AERBACP: Ethernet communication interface for Bacnet/IP and Modbus TCP/IP protocols. 1 accessory is provided for each unit control board.

AERNET: The device remotely controls, manages and remotely monitors a chiller/heat pump using a PC, smartphone or table via a Cloud connection. AERNET acts as Master while each connected unit is configured as Slave up to a maximum of 6 control cards. The connection is made via cable and/or USB key. Wi-Fi connectivity is not available. It is also possible to save a log file with all the data from the connected units to your terminal with a simple click for possible post-analysis. With the purchase of the Router, the Customer benefits from a 24-month free period during which he can use the Aernet Service at no additional cost. At the end of this initial period, the Service

may be renewed by subscribing to a 1, 2 or 3 year subscription. For further details on costs and renewal methods, please contact our office or consult the technical documentation available on our website. www.aermec.com.

AERSET: It makes it possible to automatically compensate for the operation setting of the unit to which it is connected, based on a 0-10V MODBUS input signal. Mandatory accessory MODU-485BL.

DCPX: Device for condensation temperature control, with continuous speed modulation of fans by using a pressure transducer.

MULTICHILLER-EVO: Control, switch-on and switch-off system of the single chillers where multiple units are installed in parallel (max. no. 9), always ensuring constant flow rate to the evaporators.

PRV3: Allows you to control the chiller at a distance.

DCPX: Device for condensation temperature control, with continuous speed modulation of fans by using a pressure transducer.

AVX: Spring anti-vibration supports.

FACTORY FITTED ACCESSORIES

RIF: Power factor correction. Connected in parallel to the motor allowing about 10% reduction of input current.

GP_: Anti-intrusion grid kit

KRS: Electric heater for the heat exchanger

ACCESSORIES COMPATIBILITY

Model	Ver	1402	1602	1802	2002	2202	2352	2502	2652	2802	3002	3202	3402	3602	3902
AER485P1 x no. 2	°A,E,L,N,U	*	*	*	*	*	*	*	*	*	*	*	*	*	*
AERBAC-ONE x no. 2	°A,E,L,N,U	*	*	*	*	*	*	*	*	*	*	*	*	*	*
AERBACP x no. 2	°A,E,L,N,U	*	*	*	*	*	*	*	*	*	*	*	*	*	*
AERNET	°A,E,L,N,U	*	*	*	*	*	*	*	*	*	*	*	*	*	*
AERSET	°A,E,L,N,U	*	*	*	*	*	*	*	*	*	*	*	*	*	*
MULTICHILLER-EVO	°A,E,L,N,U	*	*	*	*	*	*	*	*	*	*	*	*	*	*
PRV3	°A,E,L,N,U	*	*	*	*	*	*	*	*	*	*	*	*	*	*

Model	Ver	4202	4502	4802	5202	5602	6002	6402	6503	6703	6903	7203	8403	9603
AER485P1 x no. 2	°A,E,L,N,U	*	*	*	*	*	*	*	*	*	*	*	*	*
AER485P1 x no. 3	°A,L								*	*	*	*	*	*
	E,U								*	*	*	*	*	*
	N								*	*	*	*	*	*
AERBAC-ONE x no. 2	°A,E,L,N,U	*	*	*	*	*	*	*	*	*	*	*	*	*
AERBAC-ONE x no. 3	°A,L								*	*	*	*	*	*
	E,U								*	*	*	*	*	*
	N								*	*	*	*	*	*
AERBACP x no. 2	°A,E,L,N,U	*	*	*	*	*	*	*	*	*	*	*	*	*
AERBACP x no. 3	°A,L								*	*	*	*	*	*
	E,U								*	*	*	*	*	*
	N								*	*	*	*	*	*
AERNET	°A,L	*	*	*	*	*	*	*	*	*	*	*	*	*
	E,U	*	*	*	*	*	*	*	*	*	*	*	*	*
	N	*	*	*	*	*	*	*	*	*	*	*	*	*
AERSET	°A,L	*	*	*	*	*	*	*	*	*	*	*	*	*
	E,U	*	*	*	*	*	*	*	*	*	*	*	*	*
	N	*	*	*	*	*	*	*	*	*	*	*	*	*
MULTICHILLER-EVO	°A,L	*	*	*	*	*	*	*	*	*	*	*	*	*
	E,U	*	*	*	*	*	*	*	*	*	*	*	*	*
	N	*	*	*	*	*	*	*	*	*	*	*	*	*
PRV3	°A,L	*	*	*	*	*	*	*	*	*	*	*	*	*
	E,U	*	*	*	*	*	*	*	*	*	*	*	*	*
	N	*	*	*	*	*	*	*	*	*	*	*	*	*

Condensation control temperature

Ver	1402	1602	1802	2002	2202	2352	2502	2652	2802	3002
Fans: M										
°	DCPX110	DCPX110	DCPX110	DCPX110	DCPX110	DCPX110	DCPX110	DCPX110	DCPX111	DCPX112
A	DCPX111	DCPX111	DCPX111	DCPX111	DCPX112	DCPX112	DCPX112	DCPX112	DCPX113	DCPX113
E, L, N	As standard	As standard	As standard	As standard	As standard	As standard	As standard	As standard	As standard	As standard
U	DCPX111	DCPX111	DCPX112	DCPX112	DCPX113	DCPX113	DCPX114	DCPX114	DCPX114	DCPX114
Ver	3202	3402	3602	3902	4202	4502	4802	5202	5602	6002
Fans: M										
°	DCPX112	DCPX112	DCPX112	DCPX113	DCPX113	DCPX114	DCPX114	DCPX115	DCPX115	DCPX115
A	DCPX113	DCPX114	DCPX114	DCPX115	DCPX115	DCPX116	DCPX116	DCPX116	DCPX117	DCPX118
E, L, N	As standard	As standard	As standard	As standard	As standard	As standard	As standard	As standard	As standard	As standard
U	DCPX114	DCPX115	DCPX115	DCPX116	DCPX117	DCPX117	DCPX118	DCPX119	DCPX130	DCPX131
Ver	6402	6503	6703	6903	7203	8403	9603			
Fans: M										
°	DCPX116	DCPX135+DCPX113	DCPX135+DCPX113	DCPX125+DCPX114	DCPX114+DCPX136	DCPX114+DCPX136	DCPX114+DCPX136	DCPX114+DCPX136	DCPX114+DCPX136	DCPX114+DCPX136
A	DCPX118	DCPX115+DCPX136	DCPX115+DCPX136	DCPX116+DCPX136	DCPX116+DCPX136	DCPX117+DCPX136	DCPX117+DCPX136	DCPX117+DCPX136	-	-
E, N	As standard	As standard	As standard	As standard	As standard	As standard	As standard	As standard	-	-
L	As standard	As standard	As standard	As standard	As standard	As standard	As standard	As standard	As standard	As standard
U	DCPX132	DCPX116+DCPX137	DCPX117+DCPX137	DCPX117+DCPX137	DCPX118+DCPX137	DCPX118+DCPX137	DCPX118+DCPX137	-	-	-

The accessory cannot be fitted on the configurations indicated with -

Antivibration

Ver	1402	1602	1802	2002	2202	2352	2502	2652	2802	3002	3202	3402	3602	3902
Integrated hydronic kit: 00														
°	AVX962	AVX962	AVX962	AVX963	AVX963	AVX963	AVX963	AVX968	AVX968	AVX966	AVX966	AVX966	AVX966	AVX965
A, L	AVX963	AVX963	AVX963	AVX963	AVX964	AVX964	AVX966	AVX965	AVX965	AVX970	AVX965	AVX967	AVX967	AVX969
E, U	AVX963	AVX963	AVX964	AVX966	AVX966	AVX965	AVX965	AVX967	AVX967	AVX967	AVX967	AVX969	AVX969	AVX971
N	AVX964	AVX964	AVX987	AVX965	AVX965	AVX967	AVX967	AVX969	AVX969	AVX969	AVX969	AVX971	AVX961	AVX972
Ver	4202	4502	4802	5202	5602	6002	6402	6503	6703	6903	7203	8403	9603	
Integrated hydronic kit: 00														
°	AVX965	AVX967	AVX967	AVX969	AVX969	AVX969	AVX971	AVX978	AVX978	AVX983	AVX984	AVX984	AVX984	AVX984
A, L	AVX969	AVX971	AVX971	AVX971	AVX961	AVX972	AVX972	AVX979	AVX979	AVX980	AVX980	AVX986	AVX981	
E, U	AVX961	AVX961	AVX972	AVX972	AVX976	AVX973	AVX974	AVX980	AVX982	AVX982	AVX985	-	-	
N	AVX972	AVX973	AVX974	AVX975	AVX977	AVX977	AVX977	AVX981	-	-	-	-	-	

Power factor correction

Ver	1402	1602	1802	2002	2202	2352	2502	2652	2802	3002	3202	3402	3602	3902
°, A, E, L, N, U	RIF (1)	RIF (1)	RIF (1)	RIF (1)	RIF (1)	RIF (1)	RIF (1)	RIF (1)	RIF (1)	RIF (1)	RIF (1)	RIF (1)	RIF (1)	RIF (1)

(1) Contact the factory

A grey background indicates the accessory must be assembled in the factory

Ver	4202	4502	4802	5202	5602	6002	6402	6503	6703	6903	7203	8403	9603
°, A, L	RIF (1)	RIF (1)	RIF (1)	RIF (1)	RIF (1)	RIF (1)	RIF (1)	RIF (1)	RIF (1)	RIF (1)	RIF (1)	RIF (1)	RIF (1)
E, U	RIF (1)	RIF (1)	RIF (1)	RIF (1)	RIF (1)	RIF (1)	RIF (1)	RIF (1)	RIF (1)	RIF (1)	RIF (1)	-	-
N	RIF (1)	RIF (1)	RIF (1)	RIF (1)	RIF (1)	RIF (1)	RIF (1)	RIF (1)	-	-	-	-	-

(1) Contact the factory

A grey background indicates the accessory must be assembled in the factory

Anti-intrusion grid

Ver	1402	1602	1802	2002	2202	2352	2502	2652	2802	3002	3202	3402	3602	3902
°	GP3V	GP3V	GP3V	GP4V	GP4V	GP4V	GP4V	GP4V	GP4V	GP5V	GP5V	GP5V	GP5V	GP6V
A	GP4V	GP4V	GP4V	GP5V	GP5V	GP5V	GP5V	GP6V	GP6V	GP6V	GP6V	GP7V	GP7V	GP8V
E, U	GP4V	GP4V	GP5V	GP5V	GP5V	GP6V	GP6V	GP7V	GP7V	GP7V	GP7V	GP8V	GP8V	GP9V
L	GP4V	GP4V	GP4V	GP4V	GP5V	GP5V	GP5V	GP6V	GP6V	GP6V	GP6V	GP7V	GP7V	GP8V
N	GP5V	GP5V	GP6V	GP6V	GP6V	GP7V	GP7V	GP8V	GP8V	GP8V	GP8V	GP9V	GP10V	GP11V

A grey background indicates the accessory must be assembled in the factory

Ver	4202	4502	4802	5202	5602	6002	6402	6503	6703	6903	7203	8403	9603
°	GP6V	GP7V	GP7V	GP8V	GP8V	GP8V	GP9V	GP9V	GP9V	GP10V	GP11V	GP11V	GP11V
A, L	GP8V	GP9V	GP9V	GP9V	GP10V	GP11V	GP11V	GP4V+GP8V	GP4V+GP8V	GP5V+GP9V	GP5V+GP9V	GP5V+GP10V	GP6V+GP11V
E, U	GP10V	GP10V	GP11V	GP11V	GP6V+GP6V	GP6V+GP7V	GP7V+GP7V	GP5V+GP9V	GP5V+GP10V	GP5V+GP10V	GP6V+GP11V	-	-
N	GP11V	GP6V+GP7V	GP7V+GP7V	GP7V+GP8V	GP8V+GP8V	GP8V+GP8V	GP8V+GP8V	GP6V+GP11V	-	-	-	-	-

A grey background indicates the accessory must be assembled in the factory

Heater exchangers

Ver	1402	1602	1802	2002	2202	2352	2502	2652	2802	3002
°, A, L	KRS22	KRS22	KRS23	KRS23	KRS23	KRS23	KRS23	KRS23	KRS23	KRS23
E, N, U	KRS23	KRS23	KRS23	KRS23	KRS23	KRS23	KRS23	KRS23	KRS23	KRS23

A grey background indicates the accessory must be assembled in the factory

Ver	3202	3402	3602	3902	4202	4502	4802	5202	5602	6002
°	KRS23	KRS23	KRS23	KRS23	KRS23	KRS23	KRS24	KRS24	KRS24	KRS24
A, L	KRS23	KRS24	KRS24	KRS24	KRS24	KRS24	KRS24	KRS24	KRS24	KRS24
E, U	KRS23	KRS24	KRS24	KRS24	KRS24	KRS24	KRS24	KRS24	KRS23+KRS23	KRS23+KRS23
N	KRS23	KRS24	KRS24	KRS24	KRS24	KRS24	KRS23+KRS23	KRS23+KRS23	KRS23+KRS23	KRS23+KRS23

A grey background indicates the accessory must be assembled in the factory

Ver	6402	6503	6703	6903	7203	8403	9603
°	KRS24	KRS24	KRS24	KRS24	KRS24	KRS24	KRS24
A, L	KRS24	KRS23+KRS24	KRS23+KRS24	KRS23+KRS24	KRS23+KRS24	KRS23+KRS24	KRS23+KRS24
E, U	KRS23+KRS23	KRS23+KRS24	KRS23+KRS24	KRS23+KRS24	KRS23+KRS24	-	-
N	KRS23+KRS23	KRS23+KRS24	-	-	-	-	-

A grey background indicates the accessory must be assembled in the factory

CONFIGURATOR

Field	Description
1,2,3	NSG
4,5,6,7	Size 1402, 1602, 1802, 2002, 2202, 2352, 2502, 2652, 2802, 3002, 3202, 3402, 3602, 3902, 4202, 4502, 4802, 5202, 5602, 6002, 6402, 6503, 6703, 6903, 7203, 8403, 9603
8	Operating field
X	Electronic thermostatic expansion valve (1)
Z	Low temperature electronic thermostatic valve (2)
9	Model
°	Cooling only
10	Heat recovery
D	With desuperheater (3)
T	With total recovery (4)
°	Without heat recovery
11	Version
°	Standard
A	High efficiency
E	Silenced high efficiency
L	Standard silenced
N	Silenced very high efficiency
U	Very high efficiency
12	Coils
O	Coated aluminium microchannel
R	Copper pipes-copper fins
V	Copper pipes-Coated aluminium fins
°	Aluminium microchannel
13	Fans
J	Inverter
M	Oversized
14	Power supply
2	230V~3 50Hz with fuses (5)
4	230V~3 50Hz with magnet circuit breakers (5)
5	500V~3 50Hz with fuses (6)
8	400V~3 50Hz with magnet circuit breakers
9	500V~3 50Hz with magnet circuit breakers (6)
°	400V~3 50Hz with fuses
15,16	Integrated hydronic kit

Field	Description
00	Without hydronic kit
	Kit with n° 1 pump
PA	Pump A
PB	Pump B
PC	Pump C
PD	Pump D
PE	Pump E
PF	Pump F
PG	Pump G
PH	Pump H
PI	Pump I
PJ	Pump J (7)
	Pump n° 1 pump + stand-by pump
DA	Pump A + stand-by pump
DB	Pump B + stand-by pump
DC	Pump C + stand-by pump
DD	Pump D + stand-by pump
DE	Pump E + stand-by pump
DF	Pump F + stand-by pump
DG	Pump G + stand-by pump
DH	Pump H + stand-by pump
DI	Pump I + stand-by pump
DJ	Pump J + stand-by pump (7)
	Kit with 2 pumps
TF	Double pump F (8)
TG	Double pump G (8)
TH	Double pump H (8)
TI	Double pump I (8)
TJ	Double pump J (8)

- (1) Water produced from 0 °C ÷ 23 °C
 (2) Water produced from 8 °C ÷ -10 °C; incompatible whit D and T
 (3) The temperature of the water in the heat exchanger inlet must never drop below 35°C.
 (4) The temperature of the water in the heat exchanger inlet must never drop below 35°C. The units from 1402* - 1602* - 1802* with total recovery are not configurable. For all other sizes and versions it is to be evaluated at the order stage.
 (5) Only for sizes from 1402 to 2202
 (6) Only for sizes from 1402 to 3202
 (7) For all configurations including pump J please contact the factory.
 (8) The unit from 5603 to 9603 can only have hydronic kit "TF - TG - TH - TI - TJ"

PERFORMANCE SPECIFICATIONS

NSG - °

Size		1402	1602	1802	2002	2202	2352	2502	2652	2802	3002	3202	3402	3602	3902	
Fans: J, M																
Cooling performance 12 °C / 7 °C (1)																
Cooling capacity	kW	228,6	261,3	297,8	334,1	358,6	389,8	402,8	443,7	462,6	506,3	531,6	566,5	623,6	676,0	
Input power	kW	74,3	85,8	100,4	108,3	119,9	129,9	138,2	151,6	162,6	167,0	175,7	193,9	214,9	228,2	
Cooling total input current	A	137,90	155,90	173,50	192,40	214,50	232,70	248,40	271,40	288,60	297,20	309,40	332,10	358,70	390,20	
EER	W/W	3,08	3,05	2,97	3,08	2,99	3,00	2,91	2,93	2,85	3,03	3,02	2,92	2,90	2,96	
Water flow rate system side	l/h	39.316	44.954	51.218	57.461	61.665	67.027	69.255	76.286	79.541	87.045	91.392	97.398	107.202	116.226	
Pressure drop system side	kPa	14	18	16	21	24	20	22	18	19	17	19	21	24	29	

(1) Data EN 14511:2022; Heat exchanger water (services side) 12°C / 7°C; outside air 35°C

Size		4202	4502	4802	5202	5602	6002	6402	6503	6703	6903	7203	8403	9603
Fans: J, M														
Cooling performance 12 °C / 7 °C (1)														
Cooling capacity	kW	739,5	792,4	835,2	874,9	897,0	942,5	989,1	1060,2	1095,1	1215,2	1268,8	1333,1	1410,0
Input power	kW	251,7	263,0	281,6	288,8	302,5	320,8	329,9	355,3	375,5	407,7	419,3	461,7	512,0
Cooling total input current	A	434,20	453,50	482,00	499,70	524,20	557,60	581,10	609,40	648,80	700,80	727,80	804,60	900,50
EER	W/W	2,94	3,01	2,97	3,03	2,97	2,94	3,00	2,98	2,92	2,98	3,03	2,89	2,75
Water flow rate system side	l/h	127.152	136.250	143.578	150.403	154.212	162.036	170.045	182.263	188.254	208.871	218.093	229.141	242.359
Pressure drop system side	kPa	33	38	28	31	33	38	42	29	31	20	22	25	28

(1) Data EN 14511:2022; Heat exchanger water (services side) 12°C / 7°C; outside air 35°C

NSG - L

Size		1402	1602	1802	2002	2202	2352	2502	2652	2802	3002	3202	3402	3602	3902
Fans: J, M															
Cooling performance 12 °C / 7 °C (1)															
Cooling capacity	kW	227,7	261,7	298,7	335,0	373,6	386,8	415,2	446,3	476,8	498,0	546,8	602,0	645,3	707,0
Input power	kW	72,7	84,0	98,1	112,6	120,1	128,4	138,3	144,3	155,8	165,4	179,1	193,2	212,5	231,2
Cooling total input current	A	130,80	148,50	165,50	191,90	208,20	223,90	242,00	252,30	270,30	283,90	303,30	317,80	341,80	375,20
EER	W/W	3,13	3,12	3,04	2,97	3,11	3,01	3,00	3,09	3,06	3,01	3,05	3,12	3,04	3,06
Water flow rate system side	l/h	39.167	45.014	51.371	57.614	64.237	66.506	71.390	76.738	81.966	85.616	94.000	103.492	110.929	121.547
Pressure drop system side	kPa	15	18	17	15	19	20	16	19	16	17	19	15	18	22

(1) Data EN 14511:2022; Heat exchanger water (services side) 12°C / 7°C; outside air 35°C

Size		4202	4502	4802	5202	5602	6002	6402	6503	6703	6903	7203	8403	9603	
Fans: J, M															
Cooling performance 12 °C / 7 °C (1)															
Cooling capacity	kW	743,5	806,3	841,6	893,3	933,8	982,7	1023,0	1083,7	1120,2	1222,9	1269,4	1383,5	1517,2	
Input power	kW	252,4	266,7	283,5	297,7	306,0	315,5	334,5	357,8	379,1	402,0	421,5	465,5	504,7	
Cooling total input current	A	415,60	436,60	465,10	490,30	507,10	532,60	562,70	583,00	623,40	670,40	698,90	763,40	847,50	
EER	W/W	2,95	3,02	2,97	3,00	3,05	3,12	3,06	3,03	2,96	3,04	3,01	2,97	3,01	
Water flow rate system side	l/h	127.821	138.615	144.692	153.568	160.522	168.943	175.872	186.277	192.550	210.223	218.211	237.808	260.789	
Pressure drop system side	kPa	24	31	33	24	26	31	33	22	24	31	33	26	32	

(1) Data EN 14511:2022; Heat exchanger water (services side) 12°C / 7°C; outside air 35°C

NSG - A

Size		1402	1602	1802	2002	2202	2352	2502	2652	2802	3002	3202	3402	3602	3902
Fans: J, M															
Cooling performance 12 °C / 7 °C (1)															
Cooling capacity	kW	233,0	267,3	306,8	346,4	383,4	397,6	429,0	458,6	491,7	511,7	561,1	619,9	669,1	731,1
Input power	kW	73,5	83,8	96,7	109,8	118,4	126,0	134,9	142,3	152,7	160,7	171,9	187,9	206,4	224,9
Cooling total input current	A	138,90	154,90	170,20	194,60	214,30	229,00	245,80	259,80	276,20	287,30	302,80	321,60	344,40	379,80
EER	W/W	3,17	3,19	3,17	3,15	3,24	3,16	3,18	3,22	3,22	3,18	3,26	3,30	3,24	3,25
Water flow rate system side	l/h	40.072	45.975	52.777	59.582	65.922	68.370	73.757	78.851	84.535	87.974	96.463	106.561	115.027	125.681
Pressure drop system side	kPa	15	19	18	16	20	22	17	20	16	18	20	16	19	24

(1) Data EN 14511:2022; Heat exchanger water (services side) 12°C / 7°C; outside air 35°C

Size		4202	4502	4802	5202	5602	6002	6402	6503	6703	6903	7203	8403	9603	
Fans: J, M															
Cooling performance 12 °C / 7 °C (1)															
Cooling capacity	kW	770,4	833,7	872,2	923,2	961,9	1011,0	1053,8	1121,6	1160,9	1263,4	1313,4	1432,8	1580,6	
Input power	kW	243,7	258,6	273,6	291,5	301,9	312,6	330,2	347,1	365,9	390,3	408,0	451,1	495,6	
Cooling total input current	A	416,90	440,10	465,80	502,10	524,50	554,30	582,90	588,20	625,30	675,60	701,40	768,70	866,10	
EER	W/W	3,16	3,22	3,19	3,17	3,19	3,23	3,19	3,23	3,17	3,24	3,22	3,18	3,19	
Water flow rate system side	l/h	132.447	143.336	149.960	158.709	165.357	173.799	181.161	192.795	199.561	217.184	225.782	246.285	271.702	
Pressure drop system side	kPa	26	33	36	26	28	33	35	24	26	33	36	27	35	

(1) Data EN 14511:2022; Heat exchanger water (services side) 12°C / 7°C; outside air 35°C

NSG - E

Size		1402	1602	1802	2002	2202	2352	2502	2652	2802	3002	3202	3402	3602	3902
Fans: J, M															
Cooling performance 12 °C / 7 °C (1)															
Cooling capacity	kW	243,5	281,0	317,4	359,0	387,6	413,2	428,5	471,9	494,2	514,3	550,0	608,1	654,7	714,4
Input power	kW	73,6	86,3	96,5	111,1	122,0	126,7	133,3	144,0	153,3	160,2	172,1	188,9	204,8	222,5
Cooling total input current	A	133,10	151,80	163,40	188,50	211,30	222,00	237,30	251,20	267,00	278,80	293,20	310,30	333,50	367,70
EER	W/W	3,31	3,26	3,29	3,23	3,18	3,26	3,21	3,28	3,22	3,21	3,20	3,22	3,20	3,21
Water flow rate system side	l/h	41.877	48.309	54.578	61.723	66.638	71.045	73.675	81.134	84.968	88.414	94.560	104.538	112.548	122.817
Pressure drop system side	kPa	12	11	14	9	11	12	13	15	16	18	19	16	18	23

(1) Data EN 14511:2022; Heat exchanger water (services side) 12°C / 7°C; outside air 35°C

Size		4202	4502	4802	5202	5602	6002	6402	6503	6703	6903	7203	8403	9603	
Fans: J, M															
Cooling performance 12 °C / 7 °C (1)															
Cooling capacity	kW	764,3	813,2	877,0	900,7	944,8	1000,3	1028,9	1101,9	1151,7	1242,8	1300,9	-	-	
Input power	kW	236,0	255,6	273,4	283,8	292,9	310,2	318,7	343,0	357,9	392,1	407,8	-	-	
Cooling total input current	A	399,40	428,10	449,70	475,40	494,60	519,10	543,60	572,00	599,10	655,60	673,30	-	-	
EER	W/W	3,24	3,18	3,21	3,17	3,23	3,22	3,23	3,21	3,22	3,17	3,19	-	-	
Water flow rate system side	l/h	131.397	139.814	150.755	154.839	162.399	171.941	176.857	189.402	197.982	213.642	223.617	-	-	
Pressure drop system side	kPa	26	32	24	25	16	16	19	23	26	32	24	-	-	

(1) Data EN 14511:2022; Heat exchanger water (services side) 12°C / 7°C; outside air 35°C

NSG - U

Size		1402	1602	1802	2002	2202	2352	2502	2652	2802	3002	3202	3402	3602	3902
Fans: J, M															
Cooling performance 12 °C / 7 °C (1)															
Cooling capacity	kW	249,3	288,6	324,9	369,0	399,5	423,8	440,0	483,4	507,1	526,0	564,2	623,1	674,9	735,2
Input power	kW	74,1	85,8	96,9	110,1	120,0	126,0	132,1	143,6	152,2	157,5	167,5	185,9	201,2	218,7
Cooling total input current	A	140,70	158,00	172,50	195,70	216,90	231,40	245,80	262,60	277,20	286,80	298,40	319,30	341,50	377,40
EER	W/W	3,36	3,36	3,35	3,35	3,33	3,36	3,33	3,37	3,33	3,34	3,37	3,35	3,35	3,36
Water flow rate system side	l/h	42.866	49.623	55.869	63.446	68.694	72.874	75.659	83.113	87.181	90.438	96.990	107.116	116.011	126.384
Pressure drop system side	kPa	13	11	14	10	11	13	14	16	17	18	20	17	20	24

(1) Data EN 14511:2022; Heat exchanger water (services side) 12°C / 7°C; outside air 35°C

Size		4202	4502	4802	5202	5602	6002	6402	6503	6703	6903	7203	8403	9603	
Fans: J, M															
Cooling performance 12 °C / 7 °C (1)															
Cooling capacity	kW	784,5	837,2	901,8	927,6	971,1	1026,7	1054,7	1133,1	1182,5	1280,2	1339,0	-	-	
Input power	kW	232,3	250,1	268,3	277,9	288,3	306,2	315,5	337,3	352,2	383,1	399,1	-	-	
Cooling total input current	A	411,10	437,00	460,90	485,50	508,60	536,20	563,90	586,50	616,70	667,80	688,70	-	-	
EER	W/W	3,38	3,35	3,36	3,34	3,37	3,35	3,34	3,36	3,36	3,34	3,36	-	-	
Water flow rate system side	l/h	134.866	143.931	155.027	159.459	166.915	176.480	181.297	194.780	203.262	220.062	230.162	-	-	
Pressure drop system side	kPa	28	34	25	27	17	17	20	24	28	34	25	-	-	

(1) Data EN 14511:2022; Heat exchanger water (services side) 12°C / 7°C; outside air 35°C

NSG - N

Size		1402	1602	1802	2002	2202	2352	2502	2652	2802	3002	3202	3402	3602	3902
Fans: J, M															
Cooling performance 12 °C / 7 °C (1)															
Cooling capacity	kW	245,2	283,6	318,2	364,5	394,3	417,2	432,9	475,2	498,1	517,4	552,6	613,0	669,6	727,4
Input power	kW	73,4	84,4	95,3	107,6	118,7	124,5	130,7	141,2	149,3	156,7	165,7	182,9	200,4	216,0
Cooling total input current	A	132,00	149,30	161,80	185,30	206,80	219,10	233,80	248,50	263,60	274,00	286,50	305,60	324,20	358,70
EER	W/W	3,34	3,36	3,34	3,39	3,32	3,35	3,31	3,37	3,34	3,30	3,34	3,35	3,34	3,37
Water flow rate system side	l/h	42.156	48.766	54.716	62.663	67.797	71.743	74.443	81.707	85.643	88.946	95.006	105.378	115.107	125.049
Pressure drop system side	kPa	13	11	15	9	11	13	14	15	17	18	20	16	20	24

(1) Data EN 14511:2022; Heat exchanger water (services side) 12°C / 7°C; outside air 35°C

Size		4202	4502	4802	5202	5602	6002	6402	6503	6703	6903	7203	8403	9603	
Fans: J, M															
Cooling performance 12 °C / 7 °C (1)															
Cooling capacity	kW	766,9	834,2	880,8	925,4	961,2	1003,2	1036,3	1120,4	-	-	-	-	-	
Input power	kW	230,1	248,2	261,5	275,0	286,5	296,1	311,6	333,3	-	-	-	-	-	
Cooling total input current	A	394,50	413,50	434,70	457,50	480,40	508,60	536,80	557,20	-	-	-	-	-	
EER	W/W	3,33	3,36	3,37	3,36	3,35	3,39	3,33	3,36	-	-	-	-	-	
Water flow rate system side	l/h	131.846	143.411	151.421	159.089	165.211	172.435	178.132	192.584	-	-	-	-	-	
Pressure drop system side	kPa	27	23	29	29	17	17	20	24	-	-	-	-	-	

(1) Data EN 14511:2022; Heat exchanger water (services side) 12°C / 7°C; outside air 35°C

ENERGY INDICES (REG. 2016/2281 EU)

Size		1402	1602	1802	2002	2202	2352	2502	2652	2802	3002	3202	3402	3602	3902	
Fans: M																
SEER - 12/7 (EN14825: 2018)																
SEER	°A,E,L,N,U	W/W	(-1)	(-1)	(-1)	(-1)	(-1)	(-1)	(-1)	(-1)	(-1)	(-1)	(-1)	(-1)	(-1)	
SEPR - (EN 14825: 2018)																
SEPR	°	W/W	5,32	5,40	5,30	5,46	5,46	5,50	5,52	5,51	5,51	5,54	5,53	5,51	5,52	
	A	W/W	5,53	5,59	5,47	5,51	5,59	5,56	5,55	5,56	5,57	5,51	5,53	5,59	5,57	5,58
	E	W/W	5,69	5,72	5,77	5,64	5,58	5,71	5,65	5,72	5,67	5,65	5,67	5,64	5,66	5,68
	L	W/W	5,46	5,56	5,43	5,53	5,54	5,52	5,52	5,52	5,55	5,55	5,75	5,61	5,52	5,52
	N	W/W	5,75	5,77	5,89	5,69	5,58	5,66	5,62	5,68	5,61	5,59	5,63	5,64	5,64	5,65
U	W/W	5,73	5,78	5,81	5,70	5,65	5,76	5,71	5,77	5,72	5,70	5,72	5,70	5,72	5,74	
Water Regulation (2)		°A,E,L,N,U	type	FW/FO	FW/FO	FW/FO	FW/FO	FW/FO	FW/FO	FW/FO	FW/FO	FW/FO	FW/FO	FW/FO	FW/FO	

(1) Not covered by standard (EN14825: 2018 for comfort applications, 12°C / 7°C)

(2) VW/VO - variable water flow rate/variable outlet temperature; FW/VO - fixed water flow rate/variable outlet temperature; VW/FO - variable water flow rate/fixed outlet temperature; FW/FO - fixed water flow rate/fixed outlet temperature.

Size			4202	4502	4802	5202	5602	6002	6402	6503	6703	6903	7203	8403	9603
Fans: M															
SEER - 12/7 (EN14825: 2018)															
SEER	°A,E,L,N,U	W/W	-(1)	-(1)	-(1)	-(1)	-(1)	-(1)	-(1)	-(1)	-(1)	-(1)	-(1)	-(1)	-(1)
SEPR - (EN 14825: 2018)															
SEPR	°	W/W	5,53	5,52	5,52	5,52	5,52	5,51	5,52	5,53	5,52	5,52	5,55	5,52	5,52
	A	W/W	5,51	5,56	5,55	5,52	5,55	5,56	5,52	5,65	5,59	5,69	5,66	5,60	5,65
	E	W/W	5,69	5,64	5,69	5,56	5,56	5,56	5,69	5,81	5,86	5,67	5,72	-	-
	L	W/W	5,53	5,51	5,52	5,51	5,54	5,54	5,63	5,59	5,66	5,65	5,62	5,62	5,66
	N	W/W	5,61	5,62	5,64	5,69	5,57	5,60	5,56	5,71	-	-	-	-	-
	U	W/W	5,76	5,71	5,75	5,64	5,63	5,63	5,74	5,86	5,89	5,73	5,77	-	-
Water Regulation (2)	°A,L	type	FW/FO	FW/FO	FW/FO	FW/FO	FW/FO	FW/FO	FW/FO	FW/FO	FW/FO	FW/FO	FW/FO	FW/FO	FW/FO
	E,U	type	FW/FO	FW/FO	FW/FO	FW/FO	FW/FO	FW/FO	FW/FO	FW/FO	FW/FO	FW/FO	FW/FO	-	-
	N	type	FW/FO	FW/FO	FW/FO	FW/FO	FW/FO	FW/FO	FW/FO	FW/FO	-	-	-	-	-

(1) Not covered by standard (EN14825: 2018 for comfort applications, 12°C / 7°C)

(2) VW/VO - variable water flow rate/variable outlet temperature; FW/VO - fixed water flow rate/variable outlet temperature; VW/FO - variable water flow rate/fixed outlet temperature; FW/FO - fixed water flow rate/fixed outlet temperature.

Size			1402	1602	1802	2002	2202	2352	2502	2652	2802	3002	3202	3402	3602	3902
Fans: J																
SEER - 12/7 (EN14825: 2018)																
SEER	°	W/W	-(1)	-(1)	-(1)	-(1)	-(1)	-(1)	-(1)	-(1)	-(1)	-(1)	-(1)	-(1)	-(1)	-(1)
	A	W/W	4,43	4,40	4,48	4,54	4,51	4,54	4,56	4,56	4,56	4,56	4,57	4,57	4,56	4,57
	E	W/W	4,46	4,47	4,55	4,55	4,55	4,58	4,57	4,59	4,57	4,58	4,58	4,58	4,59	4,57
	L	W/W	4,41	4,38	4,47	4,51	4,50	4,54	4,56	4,56	4,56	4,56	4,56	4,56	4,56	4,56
	N	W/W	4,51	4,48	4,57	4,55	4,56	4,60	4,61	4,60	4,60	4,61	4,61	4,61	4,60	4,60
	U	W/W	4,48	4,47	4,56	4,57	4,56	4,58	4,57	4,59	4,58	4,59	4,59	4,59	4,59	4,60
Seasonal efficiency	°	%	-(1)	-(1)	-(1)	-(1)	-(1)	-(1)	-(1)	-(1)	-(1)	-(1)	-(1)	-(1)	-(1)	-(1)
	A	%	174,10	172,90	176,20	178,40	177,40	178,50	179,40	179,30	179,30	179,40	179,60	179,60	179,50	179,60
	E	%	175,50	175,80	178,80	179,10	179,10	180,20	179,80	180,40	179,70	180,30	180,20	180,10	180,70	179,80
	L	%	173,30	172,20	175,80	177,30	176,90	178,60	179,20	179,20	179,20	179,20	179,50	179,50	179,40	179,50
	N	%	177,40	176,20	179,60	179,00	179,50	180,80	180,80	181,40	180,90	181,00	181,20	181,40	181,10	180,90
	U	%	176,30	175,90	179,30	179,60	179,30	180,30	179,90	180,60	180,10	180,70	180,50	180,50	181,00	180,00
Water Regulation (2)	°	type	-	-	-	-	-	-	-	-	-	-	-	-	-	
	A,E,L,N,U	type	FW/VO	FW/VO	FW/VO	FW/VO	FW/VO	FW/VO	FW/VO	FW/VO	FW/VO	FW/VO	FW/VO	FW/VO	FW/VO	
SEPR - (EN 14825: 2018)																
SEPR	°	W/W	5,32	5,40	5,30	5,46	5,46	5,50	5,52	5,51	5,51	5,51	5,54	5,53	5,51	5,52
	A	W/W	5,50	5,60	5,50	5,50	5,60	5,60	5,60	5,60	5,60	5,60	5,50	5,50	5,60	5,60
	E	W/W	5,70	5,70	5,80	5,60	5,60	5,70	5,70	5,70	5,70	5,70	5,70	5,60	5,70	5,70
	L	W/W	5,50	5,60	5,40	5,50	5,50	5,50	5,50	5,50	5,60	5,60	5,80	5,60	5,50	5,50
	N	W/W	5,80	5,80	5,90	5,70	5,60	5,70	5,60	5,70	5,60	5,60	5,60	5,60	5,60	5,70
	U	W/W	5,70	5,80	5,80	5,70	5,70	5,80	5,70	5,80	5,70	5,70	5,70	5,70	5,70	5,70
Water Regulation (2)	°A,E,L,N,U	type	FW/FO	FW/FO	FW/FO	FW/FO	FW/FO	FW/FO	FW/FO	FW/FO	FW/FO	FW/FO	FW/FO	FW/FO	FW/FO	

(1) Not covered by standard (EN14825: 2018 for comfort applications, 12°C / 7°C)

(2) VW/VO - variable water flow rate/variable outlet temperature; FW/VO - fixed water flow rate/variable outlet temperature; VW/FO - variable water flow rate/fixed outlet temperature; FW/FO - fixed water flow rate/fixed outlet temperature.

Size			4202	4502	4802	5202	5602	6002	6402	6503	6703	6903	7203	8403	9603
Fans: J															
SEER - 12/7 (EN14825: 2018)															
SEER	°	W/W	-(1)	-(1)	-(1)	-(1)	-(1)	-(1)	-(1)	-(1)	-(1)	-(1)	-(1)	-(1)	-(1)
	A	W/W	4,57	4,57	4,56	4,56	4,56	4,57	4,56	4,57	4,57	4,58	4,57	4,57	4,58
	E	W/W	4,58	4,56	4,59	4,57	4,59	4,57	4,58	4,60	4,61	4,58	4,60	-	-
	L	W/W	4,56	4,56	4,55	4,56	4,56	4,56	4,55	4,57	4,56	4,57	4,57	4,56	4,57
	N	W/W	4,60	4,59	4,61	4,60	4,60	4,59	4,60	4,62	-	-	-	-	-
	U	W/W	4,59	4,57	4,59	4,57	4,59	4,58	4,59	4,61	4,61	4,58	4,60	-	-
Seasonal efficiency	°	%	-(1)	-(1)	-(1)	-(1)	-(1)	-(1)	-(1)	-(1)	-(1)	-(1)	-(1)	-(1)	-(1)
	A	%	179,60	179,60	179,30	179,50	179,40	179,60	179,40	179,90	179,60	180,00	179,80	179,80	180,00
	E	%	180,30	179,50	180,50	179,70	180,40	179,90	180,30	181,00	181,30	180,00	180,80	-	-
	L	%	179,40	179,30	179,10	179,20	179,40	179,50	179,10	179,70	179,50	179,70	179,60	179,50	179,70
	N	%	180,80	180,60	181,30	180,90	180,90	180,60	180,80	181,60	-	-	-	-	-
	U	%	180,40	179,60	180,60	179,80	180,60	180,30	180,50	181,30	181,30	180,20	180,90	-	-
Water Regulation (2)	°	type	-	-	-	-	-	-	-	-	-	-	-	-	-
	A,L	type	FW/VO	FW/VO	FW/VO	FW/VO	FW/VO	FW/VO	FW/VO	FW/VO	FW/VO	FW/VO	FW/VO	FW/VO	FW/VO
	E	type	FW/VO	FW/VO	FW/VO	FW/VO	FW/VO	FW/VO	FW/VO	FW/VO	FW/VO	FW/VO	FW/VO	-	-
	N	type	FW/VO	FW/VO	FW/VO	FW/VO	FW/VO	FW/VO	FW/VO	FW/VO	-	-	-	-	-
Water Regulation (2)	U	type	FW/VO	FW/VO	FW/VO	FW/VO	FW/VO	FW/VO	FW/VO	FW/VO	FW/VO	FW/VO	FW/VO	-	-

(1) Not covered by standard (EN14825: 2018 for comfort applications, 12°C / 7°C)

(2) VW/VO - variable water flow rate/variable outlet temperature; FW/VO - fixed water flow rate/variable outlet temperature; VW/FO - variable water flow rate/fixed outlet temperature; FW/FO - fixed water flow rate/fixed outlet temperature.

Size		4202	4502	4802	5202	5602	6002	6402	6503	6703	6903	7203	8403	9603	
SEPR - (EN 14825:2018)															
SEPR	°	W/W	5,53	5,52	5,52	5,52	5,52	5,51	5,52	5,53	5,52	5,52	5,55	5,52	5,52
	A	W/W	5,50	5,60	5,60	5,50	5,60	5,60	5,50	5,70	5,60	5,70	5,70	5,60	5,70
	E	W/W	5,70	5,60	5,70	5,60	5,60	5,60	5,70	5,80	5,90	5,70	5,70	-	-
	L	W/W	5,50	5,50	5,50	5,50	5,50	5,50	5,50	5,60	5,60	5,70	5,70	5,60	5,70
	N	W/W	5,60	5,60	5,60	5,70	5,60	5,60	5,60	5,70	-	-	-	-	-
	U	W/W	5,80	5,70	5,80	5,60	5,60	5,60	5,70	5,90	5,90	5,70	5,80	-	-
Water Regulation (2)	°A,L	type	FW/FO	FW/FO	FW/FO	FW/FO	FW/FO	FW/FO	FW/FO	FW/FO	FW/FO	FW/FO	FW/FO	FW/FO	FW/FO
	E,U	type	FW/FO	FW/FO	FW/FO	FW/FO	FW/FO	FW/FO	FW/FO	FW/FO	FW/FO	FW/FO	FW/FO	-	-
	N	type	FW/FO	FW/FO	FW/FO	FW/FO	FW/FO	FW/FO	FW/FO	FW/FO	-	-	-	-	-

(1) Not covered by standard (EN14825:2018 for comfort applications, 12°C / 7°C)

(2) VW/VO - variable water flow rate/variable outlet temperature; FW/VO - fixed water flow rate/variable outlet temperature; VW/FO - variable water flow rate/fixed outlet temperature; FW/FO - fixed water flow rate/fixed outlet temperature.

ELECTRIC DATA

Size		1402	1602	1802	2002	2202	2352	2502	2652	2802	3002	3202	3402	3602	3902	
Electric data																
Maximum current (FLA)	°	A	223,7	241,3	264,3	300,3	327,4	346,4	365,4	386,4	407,4	431,3	446,3	470,3	494,3	543,1
	A,L	A	232,6	250,2	273,2	300,3	336,3	355,3	374,3	404,1	425,1	440,1	455,1	488,0	512,0	560,9
	E,U	A	232,6	250,2	282,1	309,2	336,3	364,1	383,1	413,0	434,0	449,0	464,0	496,9	520,9	569,8
Peak current (LRA)	°	A	241,5	259,1	290,9	318,0	345,1	373,0	392,0	421,9	442,9	457,9	472,9	505,8	538,7	593,4
	°	A	252,0	287,1	329,4	376,3	395,0	442,0	459,0	486,0	493,7	597,6	636,2	665,2	661,2	791,0
	A,L	A	260,9	296,0	338,3	376,3	403,9	450,9	467,9	503,7	511,4	606,4	645,0	682,9	678,9	808,8
	E,U	A	260,9	296,0	347,2	385,2	403,9	459,7	476,7	512,6	520,3	615,3	653,9	691,8	687,8	817,7
	N	A	269,8	304,9	356,0	394,0	412,7	468,6	485,6	521,5	529,2	624,2	662,8	700,7	705,6	841,3

Size		4202	4502	4802	5202	5602	6002	6402	6503	6703	6903	7203	8403	9603	
Electric data															
Maximum current (FLA)	°	A	583,1	625,0	658,0	697,9	728,9	760,9	801,8	831,8	871,8	946,7	994,4	1.087,4	1.183,4
	A,L	A	600,9	642,8	675,8	706,8	746,7	793,4	825,4	864,3	904,3	988,1	1.021,1	1.122,9	1.236,7
	E,U	A	618,7	651,7	699,4	730,4	770,3	811,2	852,1	882,1	930,9	996,9	1.038,8	-	-
Peak current (LRA)	°	A	633,4	684,2	726,1	765,9	805,8	837,8	869,8	908,7	-	-	-	-	-
	°	A	821,3	894,2	914,2	1.078,1	1.097,9	1.209,9	1.249,8	993,9	1.024,2	1.117,1	1.151,8	1.346,4	1.520,4
	A,L	A	839,1	912,0	932,0	1.087,0	1.115,7	1.242,4	1.273,4	1.026,4	1.056,7	1.158,5	1.178,5	1.381,9	1.573,7
	E,U	A	856,9	920,9	955,6	1.110,6	1.139,3	1.260,2	1.300,1	1.044,2	1.083,3	1.167,3	1.196,2	-	-
	N	A	871,6	953,4	982,3	1.146,1	1.174,8	1.286,8	1.317,8	1.070,8	-	-	-	-	-

GENERAL TECHNICAL DATA

Size		1402	1602	1802	2002	2202	2352	2502	2652	2802	3002	3202	3402	3602	3902	
Compressor																
Type	°A,E,L,N,U	type	Screw													
Number	°A,E,L,N,U	no.	2	2	2	2	2	2	2	2	2	2	2	2	2	
Circuits	°A,E,L,N,U	no.	2	2	2	2	2	2	2	2	2	2	2	2	2	
Refrigerant	°A,E,L,N,U	type	R1234ze													
Refrigerant load circuit 1 (1)	°	kg	24,0	24,0	23,0	30,0	30,0	35,0	35,0	35,0	40,0	46,0	42,5	44,5	51,0	
	A	kg	26,5	34,0	28,0	30,5	34,0	35,0	38,5	40,5	45,0	43,0	47,0	52,0	55,0	74,0
	E	kg	29,0	30,0	41,0	34,0	40,0	43,0	43,0	46,0	45,0	45,0	57,0	54,0	74,0	60,0
	L	kg	24,0	26,0	37,0	28,0	34,0	35,0	38,5	40,0	42,0	44,0	47,0	52,0	54,0	56,0
	N	kg	36,0	38,0	34,0	44,0	49,0	53,0	56,0	60,0	64,0	64,0	55,0	72,0	81,0	85,0
	U	kg	32,0	34,0	34,0	35,0	46,0	49,0	49,0	46,0	45,0	60,0	54,5	58,0	58,0	75,0
Refrigerant load circuit 2 (1)	°	kg	24,0	25,0	25,0	41,0	33,0	38,0	37,0	37,5	35,0	50,0	48,0	46,0	59,0	
	A	kg	28,0	34,0	29,5	36,0	34,0	49,0	40,5	45,0	47,5	48,0	50,0	55,0	60,0	81,0
	E	kg	29,0	31,5	41,0	40,0	40,0	45,0	45,0	52,0	53,0	59,0	59,0	59,0	74,0	77,0
	L	kg	27,0	28,0	37,0	36,0	34,0	40,0	40,5	43,0	46,0	52,0	50,0	55,0	58,0	72,0
	N	kg	36,0	38,0	34,0	49,0	49,0	56,0	56,0	64,0	64,0	69,0	57,0	77,0	81,0	92,0
	U	kg	32,0	34,0	36,0	41,5	46,0	53,0	54,0	52,0	48,5	65,0	59,0	62,0	63,0	90,0
Potential global heating (GWP)	°A,E,L,N,U		1.37													
Equivalent CO ₂	°	tCO ₂ eq	0,06	0,06	0,07	0,08	0,08	0,09	0,09	0,09	0,10	0,11	0,12	0,12	0,13	0,14
	A	tCO ₂ eq	0,08	0,08	0,09	0,10	0,11	0,11	0,12	0,13	0,13	0,14	0,14	0,16	0,16	0,18
	E	tCO ₂ eq	0,08	0,09	0,10	0,11	0,12	0,13	0,13	0,14	0,15	0,15	0,16	0,17	0,18	0,19
	L	tCO ₂ eq	0,07	0,07	0,08	0,08	0,10	0,10	0,10	0,11	0,12	0,12	0,13	0,14	0,15	0,16
	N	tCO ₂ eq	0,10	0,10	0,12	0,12	0,13	0,14	0,14	0,15	0,16	0,16	0,17	0,18	0,20	0,21
	U	tCO ₂ eq	0,09	0,09	0,11	0,11	0,12	0,13	0,13	0,15	0,15	0,16	0,16	0,18	0,18	0,20

System side heat exchanger

Type	°A,E,L,N,U	type	Shell and tube												
Number	°A,E,L,N,U	no.	1	1	1	1	1	1	1	1	1	1	1	1	1

(1) The load indicated in the table is an estimated and preliminary value. The final value of the refrigerant load is indicated on the unit's technical label. For further information contact the office.

Size			4202	4502	4802	5202	5602	6002	6402	6503	6703	6903	7203	8403	9603
Compressor															
Type	°A,E,L,N,U	type	Screw												
Number	°A,L	no.	2	2	2	2	2	2	2	3	3	3	3	3	3
	E,U	no.	2	2	2	2	2	2	2	3	3	3	3	-	-
	N	no.	2	2	2	2	2	2	2	3	-	-	-	-	-
Circuits	°A,L	no.	2	2	2	2	2	2	2	3	3	3	3	3	3
	E,U	no.	2	2	2	2	2	2	2	3	3	3	3	-	-
	N	no.	2	2	2	2	2	2	2	3	-	-	-	-	-
Refrigerant	°A,E,L,N,U	type	R1234ze												
Refrigerant load circuit 1 (1)	°	kg	52,0	55,0	55,0	63,0	65,0	62,0	70,0	67,0	55,0	78,0	62,0	99,0	112,0
	A,L	kg	62,0	67,0	67,0	70,0	106,0	82,0	82,0	74,0	81,0	85,0	70,0	106,0	80,0
	E	kg	70,0	89,0	80,0	100,0	113,0	86,0	95,0	77,0	89,0	89,0	100,0	-	-
	N	kg	92,0	99,0	110,0	114,0	128,0	128,0	138,0	85,0	-	-	-	-	-
	U	kg	70,0	89,0	80,0	85,0	113,0	86,0	95,0	77,0	89,0	89,0	100,0	-	-
Refrigerant load circuit 2 (1)	°	kg	59,0	64,0	64,0	70,0	71,0	73,0	80,0	74,0	61,0	85,0	70,0	99,0	112,0
	A	kg	70,0	78,0	78,0	82,0	106,0	99,0	99,0	81,0	81,0	92,0	75,0	106,0	95,0
	E	kg	85,0	96,0	90,0	110,0	113,0	98,0	97,0	85,0	89,0	96,0	100,0	-	-
	L	kg	70,0	79,0	78,0	82,0	106,0	99,0	99,0	81,0	81,0	92,0	75,0	106,0	95,0
	N	kg	92,0	107,0	110,0	124,0	128,0	138,0	138,0	92,0	-	-	-	-	-
Refrigerant load circuit 3 (1)	U	kg	85,0	96,0	90,0	103,0	113,0	98,0	97,0	85,0	89,0	96,0	100,0	-	-
	°	kg	-	-	-	-	-	-	74,0	65,0	85,0	80,0	99,0	112,0	
	A,L	kg	-	-	-	-	-	-	81,0	81,0	92,0	75,0	106,0	85,0	
	E,U	kg	-	-	-	-	-	-	85,0	89,0	96,0	100,0	-	-	
	N	kg	-	-	-	-	-	-	92,0	-	-	-	-	-	
Potential global heating (GWP)	°A,E,L,N,U		1.37												
Equivalent CO ₂	°	tCO ₂ eq	0,15	0,16	0,17	0,18	0,19	0,20	0,22	0,21	0,22	0,24	0,25	0,29	0,33
	A	tCO ₂ eq	0,18	0,20	0,21	0,22	0,24	0,25	0,27	0,27	0,28	0,30	0,31	0,35	0,40
	E	tCO ₂ eq	0,21	0,22	0,24	0,25	0,27	0,28	0,30	0,30	0,32	0,33	0,35	-	-
	L	tCO ₂ eq	0,17	0,18	0,19	0,20	0,22	0,23	0,24	0,24	0,25	0,28	0,28	0,32	0,37
	N	tCO ₂ eq	0,22	0,25	0,26	0,28	0,30	0,31	0,32	0,32	-	-	-	-	-
U	tCO ₂ eq	0,21	0,22	0,24	0,25	0,27	0,29	0,31	0,30	0,32	0,34	0,36	-	-	
System side heat exchanger															
Type	°A,E,L,N,U	type	Shell and tube												
Number	°	no.	1	1	1	1	1	1	1	1	1	1	1	1	1
	A,L	no.	1	1	1	1	1	1	1	2	2	2	2	2	2
	E,U	no.	1	1	1	1	2	2	2	2	2	2	2	-	-
	N	no.	1	2	2	2	2	2	2	2	-	-	-	-	-

(1) The load indicated in the table is an estimated and preliminary value. The final value of the refrigerant load is indicated on the unit's technical label. For further information contact the office.

FANS DATA

Size			1402	1602	1802	2002	2202	2352	2502	2652	2802	3002	3202	3402	3602	3902
Fan																
Type	°A,E,L,N,U	type	Axial	Axial	Axial	Axial	Axial	Axial	Axial	Axial	Axial	Axial	Axial	Axial	Axial	Axial
Number	°	no.	6	6	6	8	8	8	8	8	8	10	10	10	10	12
	A,L	no.	8	8	8	8	10	10	10	12	12	12	12	14	14	16
	E,U	no.	8	8	10	10	10	12	12	14	14	14	14	16	16	18
	N	no.	10	10	12	12	12	14	14	16	16	16	16	18	20	22
System side heat exchanger																
Type	°A,E,L,N,U	type	Axial	Axial	Axial	Axial	Axial	Axial	Axial	Axial	Axial	Axial	Axial	Axial	Axial	Axial
Number	°	no.	12	14	14	16	16	16	18	18	18	20	22	22	22	22
	A,L	no.	16	18	18	18	20	22	22	24	24	28	28	30	34	
	E,U	no.	20	20	22	22	24	26	28	28	30	30	32	-	-	
	N	no.	22	26	28	30	32	32	32	34	-	-	-	-	-	

Oversized

Size			1402	1602	1802	2002	2202	2352	2502	2652	2802	3002	3202	3402	3602	3902
Fans: M																
Increased fan																
Fan motor	°A,U	type	Asynchronous													
	E,L,N	type	Asynchronous with phase cut													
Without Static pressure																
Air flow rate	°	m ³ /h	108000	108000	108000	144000	144000	144000	144000	144000	144000	180000	180000	180000	180000	216000
	A	m ³ /h	144000	144000	144000	144000	180000	180000	180000	216000	216000	216000	216000	252000	252000	288000
	E	m ³ /h	92000	92000	115000	115000	115000	138000	138000	161000	161000	161000	161000	184000	184000	207000
	L	m ³ /h	92000	92000	92000	92000	115000	115000	115000	138000	138000	138000	138000	161000	161000	184000
	N	m ³ /h	115000	115000	138000	138000	138000	161000	161000	184000	184000	184000	184000	207000	230000	253000
	U	m ³ /h	144000	144000	180000	180000	180000	216000	216000	252000	252000	252000	252000	288000	288000	324000
Sound power level	°	dB(A)	98,0	98,0	98,0	98,0	98,0	98,0	98,0	98,0	98,0	99,0	99,0	100,0	100,0	101,0
	A	dB(A)	98,0	98,0	99,0	99,0	99,0	99,0	100,0	100,0	100,0	100,0	100,0	100,0	100,0	101,0
	E	dB(A)	89,0	89,0	90,0	90,0	90,0	91,0	91,0	92,0	92,0	92,0	92,0	93,0	93,0	93,0
	L	dB(A)	89,0	89,0	89,0	89,0	90,0	91,0	91,0	91,0	91,0	91,0	91,0	91,0	91,0	92,0
	N	dB(A)	90,0	90,0	91,0	91,0	91,0	91,0	91,0	92,0	92,0	92,0	92,0	93,0	93,0	93,0
	U	dB(A)	98,0	98,0	99,0	99,0	99,0	100,0	100,0	100,0	100,0	100,0	100,0	101,0	101,0	101,0

Size			4202	4502	4802	5202	5602	6002	6402	6503	6703	6903	7203	8403	9603	
Fans: M																
Increased fan																
Fan motor	°A,U	type	Asynchronous													
	E,L,N	type	Asynchronous with phase cut													
Without Static pressure																
Air flow rate	°	m ³ /h	216000	252000	252000	288000	288000	288000	324000	324000	324000	360000	396000	396000	396000	396000
	A	m ³ /h	288000	324000	324000	324000	360000	396000	396000	432000	432000	504000	504000	540000	612000	
	E	m ³ /h	230000	230000	253000	253000	276000	299000	322000	322000	345000	345000	368000	-	-	
	L	m ³ /h	184000	207000	207000	234000	260000	286000	286000	276000	276000	322000	322000	345000	442000	
	N	m ³ /h	253000	299000	322000	345000	368000	368000	368000	391000	-	-	-	-	-	
	U	m ³ /h	360000	360000	396000	396000	432000	468000	504000	504000	540000	540000	576000	-	-	
Sound power level	°	dB(A)	101,0	101,0	101,0	102,0	102,0	102,0	102,0	102,0	102,0	103,0	103,0	103,0	103,0	
	A	dB(A)	101,0	101,0	102,0	101,0	102,0	102,0	102,0	103,0	103,0	103,0	103,0	104,0	104,0	
	E	dB(A)	94,0	94,0	94,0	94,0	94,0	94,0	94,0	94,0	94,0	94,0	95,0	-	-	
	L	dB(A)	93,0	93,0	93,0	93,0	94,0	94,0	94,0	94,0	94,0	94,0	94,0	94,0	95,0	
	N	dB(A)	93,0	94,0	94,0	95,0	95,0	95,0	95,0	95,0	-	-	-	-	-	
	U	dB(A)	102,0	102,0	102,0	102,0	103,0	103,0	103,0	103,0	103,0	103,0	103,0	-	-	

Inverter

Size			1402	1602	1802	2002	2202	2352	2502	2652	2802	3002	3202	3402	3602	3902
Fans: J																
Inverter fan																
Fan motor	°A,E,L,N,U	type	Inverter													
	°	m ³ /h	96000	96000	96000	128000	128000	128000	128000	144000	144000	180000	180000	180000	180000	216000
Air flow rate	A	m ³ /h	128000	128000	128000	128000	160000	160000	160000	192000	192000	192000	192000	224000	224000	256000
	E	m ³ /h	92000	92000	115000	115000	115000	138000	138000	161000	161000	161000	161000	184000	184000	207000
	L	m ³ /h	92000	92000	92000	92000	115000	115000	115000	138000	138000	138000	138000	161000	161000	184000
	N	m ³ /h	115000	115000	138000	138000	138000	161000	161000	184000	184000	184000	184000	207000	230000	253000
	U	m ³ /h	128000	128000	160000	160000	160000	192000	192000	224000	224000	224000	224000	256000	256000	288000
Sound data calculated in cooling mode (1)																
Sound power level	°	dB(A)	96,8	97,0	97,2	97,6	97,8	98,0	98,2	98,4	98,4	99,4	99,5	99,6	99,8	100,7
	A	dB(A)	97,3	97,4	97,8	97,9	98,2	98,3	98,4	98,8	98,9	99,0	99,1	99,3	99,4	100,1
	E	dB(A)	89,3	89,4	90,2	90,3	90,4	90,8	91,2	91,8	92,0	92,2	92,3	92,8	93,0	93,2
	L	dB(A)	88,9	89,0	89,1	89,2	90,3	90,5	90,6	90,8	90,9	91,0	91,1	91,3	91,4	92,4
	N	dB(A)	90,0	90,4	90,9	91,0	91,1	91,4	91,4	92,1	92,2	92,3	92,4	92,8	93,1	93,3
U	dB(A)	97,0	97,4	98,0	98,2	98,4	98,8	98,8	99,0	99,1	99,2	99,3	99,9	100,0	100,4	

(1) Sound power: calculated on the basis of measurements made in accordance with UNI EN ISO 9614-2, as required for Eurovent certification. Sound pressure measured in free field (in compliance with UNI EN ISO 3744).

Size		4202	4502	4802	5202	5602	6002	6402	6503	6703	6903	7203	8403	9603
Fans: J														
Inverter fan														
Fan motor	°A,E,L,N,U	Inverter												
	°	m ³ /h	216000	252000	252000	288000	288000	288000	324000	324000	324000	360000	396000	396000
	A	m ³ /h	256000	288000	288000	324000	360000	396000	396000	384000	384000	448000	480000	612000
Air flow rate	E	m ³ /h	230000	230000	253000	253000	276000	299000	322000	322000	345000	345000	368000	-
	L	m ³ /h	184000	207000	207000	234000	260000	286000	286000	276000	276000	322000	322000	345000
	N	m ³ /h	253000	299000	322000	345000	368000	368000	368000	391000	-	-	-	-
	U	m ³ /h	320000	320000	352000	352000	384000	416000	448000	448000	480000	480000	512000	-
Sound data calculated in cooling mode (1)														
	°	dB(A)	100,8	101,2	101,3	101,7	101,7	101,8	102,1	102,3	102,4	103,0	103,1	103,2
	A	dB(A)	100,2	100,4	100,8	101,5	101,7	101,9	102,0	102,0	102,1	102,3	102,4	103,3
Sound power level	E	dB(A)	93,5	93,6	93,7	93,8	93,9	94,0	94,2	94,3	94,3	94,4	94,8	-
	L	dB(A)	92,5	93,0	93,1	93,2	93,7	93,9	94,0	94,2	94,2	94,3	94,4	95,0
	N	dB(A)	93,4	94,3	94,4	94,8	95,0	95,2	95,3	95,4	-	-	-	-
	U	dB(A)	100,7	101,0	101,3	101,6	102,0	102,1	102,2	102,2	102,3	102,4	102,4	-

(1) Sound power: calculated on the basis of measurements made in accordance with UNI EN ISO 9614-2, as required for Eurovent certification. Sound pressure measured in free field (in compliance with UNI EN ISO 3744).

DIMENSIONS

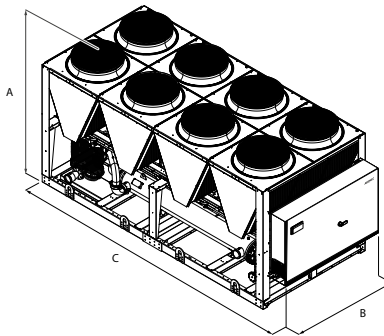

Dimensions

Size		1402	1602	1802	2002	2202	2352	2502	2652	2802	3002	3202	3402	3602	3902
Dimensions and weights															
A	°A,E,L,N,U	mm	2450	2450	2450	2450	2450	2450	2450	2450	2450	2450	2450	2450	2450
B	°A,E,L,N,U	mm	2200	2200	2200	2200	2200	2200	2200	2200	2200	2200	2200	2200	2200
	°	mm	3970	3970	3970	5160	5160	5160	5160	5160	6350	6350	6350	6350	7540
C	A,L	mm	5160	5160	5160	5160	6350	6350	6350	7540	7540	7540	8730	8730	9920
	E,U	mm	5160	5160	6350	6350	6350	7540	7540	8730	8730	8730	9920	9920	11110
	N	mm	6350	6350	7540	7540	7540	8730	8730	9920	9920	9920	11110	12300	13490
Dimensions and weights															
	°A,L	mm	2450	2450	2450	2450	2450	2450	2450	2450	2450	2450	2450	2450	2450
A	E,U	mm	2450	2450	2450	2450	2450	2450	2450	2450	2450	2450	2450	-	-
	N	mm	2450	2450	2450	2450	2450	2450	2450	2450	-	-	-	-	-
	°A,L	mm	2200	2200	2200	2200	2200	2200	2200	2200	2200	2200	2200	2200	2200
B	E,U	mm	2200	2200	2200	2200	2200	2200	2200	2200	2200	2200	2200	-	-
	N	mm	2200	2200	2200	2200	2200	2200	2200	2200	-	-	-	-	-
	°	mm	7540	8730	8730	9920	9920	9920	11110	11110	11110	12300	13490	13490	13490
C	A,L	mm	9920	11110	11110	11110	12300	13490	13490	15080	15080	17460	17460	18650	21030
	E,U	mm	12300	12300	13490	13490	15080	16270	17460	17460	18650	18650	19840	-	-
	N	mm	13490	16270	17460	18650	19840	19840	19840	21030	-	-	-	-	-

For transport reasons, the units with the depth of more than 13090 mm are shipped separately. For more information, please refer to the technical manual and / or installation.

Size		1402	1602	1802	2002	2202	2352	2502	2652	2802	3002	3202	3402	3602	3902
Integrated hydronic kit: 00															
Single module unit															
	°	kg	4.108	4.153	4.275	5.137	5.468	5.476	5.485	5.680	5.690	6.659	7.153	7.163	7.188
	A	kg	4.637	4.684	4.806	5.137	5.882	5.890	6.085	6.696	6.782	7.261	7.806	8.486	8.501
Empty weight	E	kg	4.768	4.800	5.220	5.814	6.145	6.755	6.763	7.198	7.213	7.707	7.806	8.940	8.950
	L	kg	4.637	4.684	4.806	5.137	5.882	5.890	6.085	6.696	6.782	7.261	8.223	8.486	8.501
	N	kg	5.179	5.214	5.822	6.415	6.746	7.163	7.177	7.649	7.659	8.161	8.223	9.630	10.062
	U	kg	4.768	4.800	5.220	5.814	6.145	6.755	6.763	7.198	7.213	7.707	8.672	8.940	8.950

Size		1402	1602	1802	2002	2202	2352	2502	2652	2802	3002	3202	3402	3602	3902	
Weight functioning	°	kg	4.186	4.225	4.393	5.256	5.586	5.614	5.622	5.953	5.962	6.982	7.475	7.485	7.501	8.166
	A	kg	4.714	4.757	4.925	5.275	6.019	6.028	6.357	6.968	7.105	7.583	8.098	9.016	9.030	9.547
	E	kg	4.887	4.937	5.358	6.137	6.467	7.077	7.086	7.510	7.525	8.019	8.098	9.470	9.480	10.237
	L	kg	4.714	4.757	4.925	5.275	6.019	6.028	6.357	6.968	7.105	7.583	8.515	9.016	9.030	9.547
	N	kg	5.298	5.352	5.959	6.738	7.069	7.486	7.500	7.961	7.971	8.474	8.515	10.160	10.592	11.199
	U	kg	4.887	4.937	5.358	6.137	6.467	7.077	7.086	7.510	7.525	8.019	8.964	9.470	9.480	10.237
Size		4202	4502	4802	5202	5602	6002	6402	6503	6703	6903	7203	8403	9603		
Integrated hydronic kit: 00																
Single module unit																
Empty weight	°	kg	7.947	8.389	8.704	9.252	9.347	9.405	10.170	11.843	11.931	12.488	13.081	13.400	13.552	
	A,L	kg	9.090	9.829	9.892	10.315	10.836	11.441	11.519	-	-	-	-	-	-	
	E,U	kg	10.203	10.282	11.194	11.284	-	-	-	-	-	-	-	-	-	
	N	kg	10.748	-	-	-	-	-	-	-	-	-	-	-	-	
Weight functioning	°	kg	8.239	8.681	9.234	9.781	9.877	9.922	10.687	12.797	12.885	13.398	13.990	14.309	14.462	
	A,L	kg	9.608	10.334	10.397	11.247	11.767	12.358	12.437	-	-	-	-	-	-	
	E,U	kg	10.720	10.787	12.125	12.215	-	-	-	-	-	-	-	-	-	
	N	kg	11.265	-	-	-	-	-	-	-	-	-	-	-	-	
Bimodule unit																
Empty weight module 1	°	kg	-	-	-	-	-	-	-	-	-	-	-	-	-	
	A,L	kg	-	-	-	-	-	-	9.029	9.090	9.829	9.892	10.836	11.519		
	E,U	kg	-	-	-	-	6.276	6.276	6.741	9.719	10.203	10.282	11.194	-	-	
	N	kg	-	6.084	6.517	6.517	7.126	7.126	7.190	10.880	-	-	-	-	-	
Empty weight module 2	°	kg	-	-	-	-	-	-	-	-	-	-	-	-		
	A,L	kg	-	-	-	-	-	-	5.068	5.068	5.512	5.512	5.675	6.265		
	E,U	kg	-	-	-	-	6.207	6.671	6.671	5.482	5.482	5.512	5.512	-	-	
	N	kg	-	6.448	6.448	7.056	7.056	7.120	7.120	6.014	-	-	-	-	-	
Total empty weight	°	kg	-	-	-	-	-	-	-	-	-	-	-	-		
	A,L	kg	-	-	-	-	-	-	14.098	14.159	15.342	15.405	16.511	17.784		
	E,U	kg	-	-	-	-	12.483	12.948	13.412	15.202	15.685	15.795	16.706	-	-	
	N	kg	-	12.531	12.965	13.573	14.182	14.246	14.310	16.894	-	-	-	-	-	
Weight functioning module 1	°	kg	-	-	-	-	-	-	-	-	-	-	-	-		
	A,L	kg	-	-	-	-	-	-	9.547	9.608	10.334	10.397	11.767	12.437		
	E,U	kg	-	-	-	-	6.589	6.589	7.053	10.237	10.720	10.787	12.125	-	-	
	N	kg	-	6.342	6.776	6.776	7.438	7.438	7.502	11.398	-	-	-	-	-	
Weight functioning module 2	°	kg	-	-	-	-	-	-	-	-	-	-	-	-		
	A,L	kg	-	-	-	-	-	-	5.327	5.327	5.771	5.771	5.987	6.577		
	E,U	kg	-	-	-	-	6.519	6.984	6.984	5.741	5.741	5.771	5.771	-	-	
	N	kg	-	6.706	6.706	7.369	7.369	7.433	7.433	6.273	-	-	-	-	-	
Total weight functioning	°	kg	-	-	-	-	-	-	-	-	-	-	-	-		
	A,L	kg	-	-	-	-	-	-	14.874	14.935	16.105	16.168	17.755	19.014		
	E,U	kg	-	-	-	-	13.108	13.572	14.037	15.978	16.461	16.558	17.896	-	-	
	N	kg	-	13.049	13.482	14.144	14.807	14.871	14.935	17.670	-	-	-	-	-	

Aermec reserves the right to make any modifications deemed necessary.
All data is subject to change without notice. Aermec does not assume responsibility or liability for errors or omissions.

Aermec S.p.A.
Via Roma, 996 - 37040 Bevilacqua (VR) - Italia
Tel. 0442633111 - Telefax 044293577
www.aermec.com